

Lift and Dispense a Drum

Video at www.MorseDrum.com

MADE
IN
USA

- You Control Lifting Height and Pouring Angle
- Removes Effort and Increases Productivity
- Power Lift and Tilt Options
- Heavy-Duty Hydraulics
- 360° Tilt Control in Either Direction
- Available with Spark Resistant Parts
- Capacity: 800 Lb. (363 kg) full drum (500 Lb. (227 kg) half-full* drum)

A fully loaded drum is easily handled by one person with a Morse Hydra-Lift Karrier. Lift, move and control pouring of a 55-gallon (210 liter) drum weighing up to 800 Lb. with minimal physical effort. Handle a variety of drums by installing the correct accessories for your particular size and type of drum. Standard models are available with maximum pouring heights of 60", 72" or 96". Custom versions can be made for extra lift, more reach, greater straddle width, non-standard containers, etc.

You can raise and control dispensing as necessary. Increase pouring angle for full discharge, reduce to control the pour rate, or reverse to stop pouring and deliver partial drum contents.

Material is discharged straight forward directly from the drum. Faucets, pipe, valve extensions, etc. may be attached to the drum, but the ability to pour straight from the drum with variable lift and pour angles is an important difference from chute type dumpers.

Though often used for lifting and pouring, the Hydra-Lift Karrier can be used in various ways, such as lifting drums on or off scales, platforms, conveyors or trucks, moving drums to or from storage, charging high tanks and positioning drums of parts for hand access at work stations.



Model 400A-96-110 with 96" dispensing height and electric power lift and tilt.

NEW MORCINCH Drum Handling System

- Automatically adjusts for 22" to 23.5" diameter drum
- Accepts Diameter Adaptors for your smaller drum
- Accepts bolt-on Top Rim Clamp or Bracket Assembly to handle a plastic or fiber drum
- Includes a flexible cover on the cinch chain to help protect the sidewall of your drum
- Incorporates alloy cinch chain and hinge, and durable stress relief weld joints

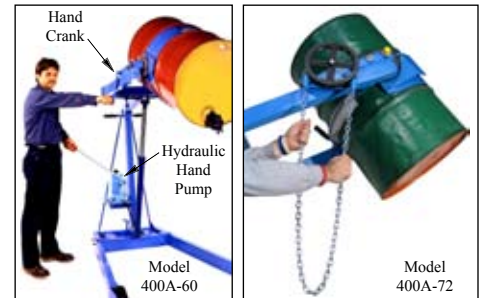

Each Hydra-Lift Karrier Features

Heavy-duty hydraulic ram with a built-in flow control for a uniform, controlled speed of descent with even the heaviest drum.

Welded rectangular steel tube framework.

Easy maneuverability on two 8" (20.3 cm) durable polyolefin wheels and two 4" (10.2 cm) swivel casters hidden under the base.

A screw down floor lock.

Manual-Lift Models have hydraulic hand pump with variable release valve for drum lift.

Manual-Tilt Models have covered tilt gears with 30:1 reduction to make pouring your drum simple and easy.

See power lift and power tilt options on side 2.

Manual Tilt Models

- Model 400A-60 has hand crank tilt control and 60" lift height.
- Models 400A-72 and 400A-96 have pull chain and chain wheel tilt control, with 72" or 96" lift height respectively.

Manual Tilt Control Options

We recommend Option # 3900i-P factory installed MORStop Tilt-Brake to automatically hold tilt angle.

Part # 3900-P

MORStop Tilt-Brake Kit to field install behind the chain wheel or hand crank on your Hydra-Lift Karrier.

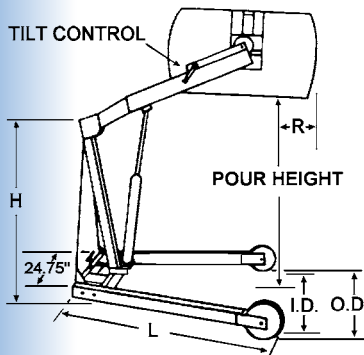

Model #	Dispensing Height	R	H	L	O.D.	I.D.	Tilt Control	Ship Weight
400A-60	60" (152 cm)	12"	55"	60"	44"	37"	Hand Crank	308 Lb.
400A-72	72" (183 cm)	6"	55"	60"	44"	37"	Chain Wheel	311 Lb.
400A-96	96" (244 cm)	-4"	69"	72.5"	49"	42"	Chain Wheel	379 Lb.
400S	Special height, reach, straddle, capacity, non-standard drum, etc.							

Model numbers in this chart include hand pump hydraulic lift and manual drum tilt control. See available power options on side 2. The 400AM Series is available with spark resistant parts. Custom models are available in type 304 stainless steel.

Option X01

Hand Crank with MORStop Tilt-Brake.

Option X02 Simple Hand Crank.

Option X03

16" Hand Wheel (not shown).



* Half-full rating is based on tilt mechanism's capacity for handling a bottom heavy drum. A partially full drum with unbalanced and shifting load is harder to tilt than a full drum.

To order complete units with any of the power options below, use the power option number as a suffix on manual model number. Example: Model 400A-96-115 is 96" lift model with battery powered lift and tilt. Power-Tilt Options must be ordered on new units from the factory. All units with power options factory installed are shipped fully assembled.

Power Lift Options

Power-Lift Options ease drum lifting, but retain manual tilt control. Hand crank tilt control is on 60" lift height units. Models with 72" and 96" lift heights have pull chain and chain wheel tilt control.

Power Option #	Motor Type	Motor Control	Ship Wt. Adder
120	AC, 1HP/115V, TEFC	Switch, Cord, Plug	40 Lb.
124	Air, Vane Type	On/Off Valve	25 Lb.
125	DC, 12V	Built-in	85 Lb.



Electric Power Lift Option #120

Use switch to raise the drum. Lower the drum with manual release valve.



Air Motor Power Lift Option #124

Use on/off valve to raise the drum. Lower the drum with manual release valve.



Battery Power Lift Option #125

Self contained battery power-lift. Use valve to raise and lower the drum. Separate charger is included.

Existing manual lift models can be converted to power lift. Order Power-Lift Kit for "Field installation," such as O-120FI, O-124FI, or O-125FI.

Power Lift and Tilt Options

Power Lift and Tilt Options make drum handling easier and faster. There are two hand valve controls: One for the power-lift function and a second for power-tilt.

Power Option #	Motor Type	Motor Control	Ship Wt. Adder
110	AC, 1HP/115V, TEFC	Switch, Cord, Plug	75 Lb.
114	Air, Vane Type	On/Off Valve	95 Lb.
115	DC, 12V	Built-in	120 Lb.



Electric Power Lift & TILT Option #110

Similar to Option 120 above, except with a second valve controlling the hydraulically driven drum tilt.



Air Power Lift and Tilt Option #114

Similar to Option 124 above, except with a second valve controlling the hydraulically driven drum tilt.



Battery Power Lift and Tilt Option #115

Similar to Option 125 above, except with a second valve controlling the hydraulically driven drum tilt.

Please contact your Morse dealer

MORCINCH Options

The MORCINCH drum holder on Hydra-Lift Karriers is designed to handle a 55-gallon steel or fiber drum. It automatically adjusts from 22" to 23.5" in diameter. The cinch chain with pawl and ratchet mechanism is used to secure the drum in the holder.

To handle other drums, order one of the following:

The **Bracket Assembly** provides a brace at top and bottom of your drum to prevent it from slipping lengthways through the drum holder. The Bracket Assembly is required to handle a rimless plastic drum, and recommended to more securely handle a fiber drum. It adjusts for 31" to 39" tall drum.

Part # 4556-P Bracket Assembly.

Part # 4556M-P Spark Resistant Bracket Assembly.

The **Top Rim Clamp** grips the upper rim of your drum to prevent it from slipping through the drum holder. Use to handle a 55-gallon rimmed plastic or fiber drum. To handle a 55-gallon plastic drum with top rim, you must install either the Bracket Assembly or the Top Rim Clamp.

Part # 4560-P Rim Clamp Assembly.

Part # 4560M-P Spark Resistant Rim Clamp Assembly.

For a smaller diameter drum, Diameter Adaptors fit inside the drum holder. They install easily

without tools and are quickly removed.



55/30-17.5

Diameter Adaptors for 17.5" diameter or smaller have brackets at top and bottom of the drum. They adjust for a drum up to 38" tall. Spark resistant and stainless steel Diameter Adaptors are also available.

DIAMETER ADAPTORS

DIAMETER ADAPTORS	SPARK RESISTANT DIAMETER ADAPTORS	STAINLESS STEEL DIAMETER ADAPTORS	FITS DIAMETER	SHIP WEIGHT
55/30-20.5	55/30M-20.5	55/30SS-20.5	20" to 20.5"	23 Lb.
55/30-19	55/30M-19	55/30SS-19	18.5" to 19"	24 Lb.
55/30-17.5	55/30M-17.5	55/30SS-17.5	17" to 17.5"	35 Lb.
55/30-16	55/30M-16	55/30SS-16	15.5" to 16"	35 Lb.
55/30-14.5	55/30M-14.5	55/30SS-14.5	14" to 14.5"	36 Lb.

Optional 3-Piece Drum Holder

Option # G-400

The optional 3-Piece Drum Holder is for handling only a 22.5" diameter 55-gallon steel drum. It surrounds your drum with a hinged metal band.



MADE IN USA